

2/2 way direct acting solenoid valve, NO

Product Information



A. u. K. Müller

Solenoid valves
Control valves
Special valves and systems

A. u. K. Müller GmbH & Co. KG
Dresdener Str. 162
D-40595 Düsseldorf/Germany

Tel.: +49(0)211-7391-0
Fax: +49(0)211-7391-281

e-mail: info@akmueller.de
Internet: www.akmueller.de

Series 18.00x.001



Characteristics

- Direct acting
- Compact design
- Long term performance capability
- Suitable for food and hot water appliances
- Works from zero pressure
- Easy to assemble and service
- Coil change without opening of medium circuit, coil can be mounted 4 x 90°
- High operating safety by the use of high quality materials and 100% final testing of the products

Applications

- Saturated steam applications up to 143 °C
- Steam cleaners and ironing machines
- Hot / cold drink dispensers (espresso makers)
- Medical equipment
- Industrial applications

Description

2/2-way solenoid valve of several nominal diameters for use with neutral gases and liquids. This valve is direct acting and normally open (NO).

Valves of this design are single chamber straight through valves, with threaded tube clamp or push-fit connections at outlet and inlet.

The valve body is made of PPSU, which is suitable for hot water applications.

This valve is designed for continuous operation (duty cycle 100%).

Electrical operating safety is achieved by using high quality materials of insulation class F.

Type	DN
18.002.001	1,2
18.003.001	1,5
18.004.001	2,0
18.005.001	2,5

typical performance curve

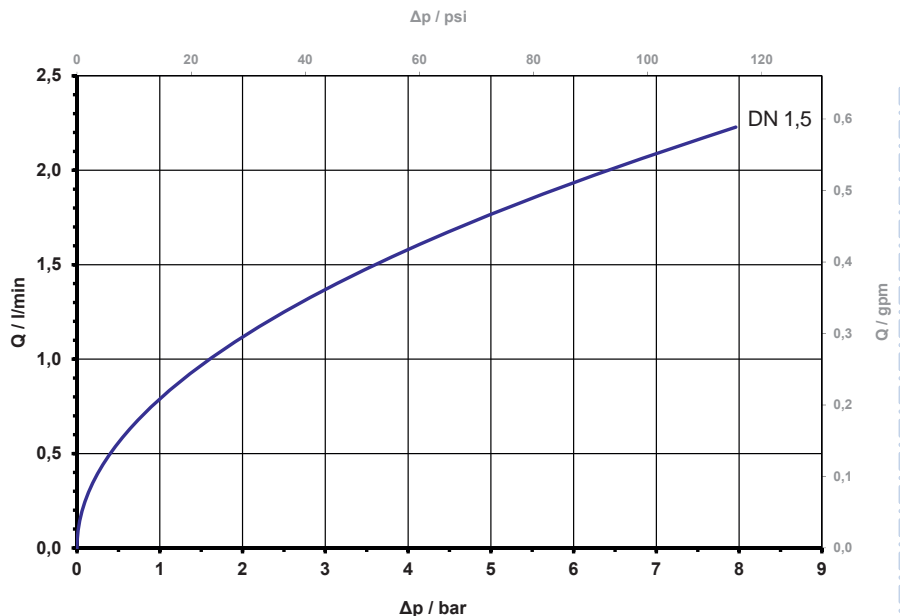



Series I8.00x.001

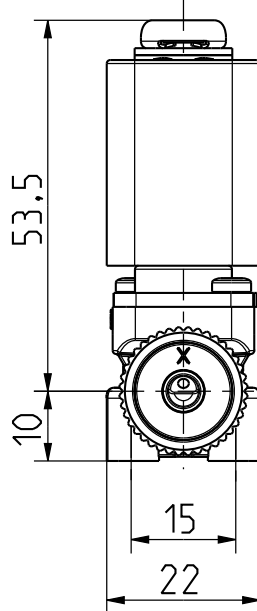
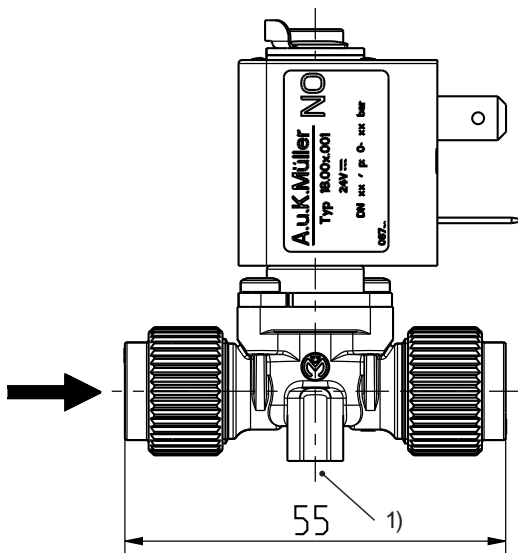

1) Fixing possibility for self tapping screw $\varnothing 3,8 \times 9$

Technical Data

Type	Solenoid valve	
Construction	2/2-way single chamber straight valve, direct acting	
Function	NO (normally open)	
Fitting position	Any	
Media	Neutral gases, cold and heated potable water and physically and chemically similar media	
T-Medium	98	°C max.
Saturated steam	143 (3 bar)	°C max.
T-Ambient	50	°C max.
DN		
Cv-value	See page 3	
p-Operating		
Coil type	MS.037	
Nominal voltage	24	V DC
	Other voltages on request	
Voltage tolerance	+10% - 15%	
Duty cycle	100%	
Nominal power	8,3 W	
Protection Type	IP 65	
Coil connections	Plug socket flat tap 6,3 x 0,8 mm model B-industry form	
Insulation class	F	according to EN 60730
Protection class	I	according to EN 60730 (for incorporation in class I)

Materials

Valve body	PPSU
Plunger guide	Stainless steel
Plunger	Stainless steel
Seal	EPDM
Coil coating	PA, EP or PPS

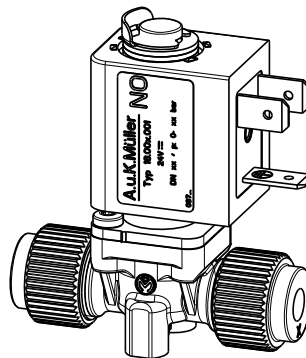

Options

Tube material	Dimension outer \varnothing x wall thickness	
Flexible plastic tubes	6 x 1	
Metal tubes	6 x 1	to be equipped with special cut-in by user

Other orifice sizes (DN) are in preparation

⚠ PPSU valve bodies may not come in contact with:
acetone, ethers, ketones, aromatic hydrocarbons, chlorinated hydrocarbons, acids and oxidizing anaerobic adhesives.

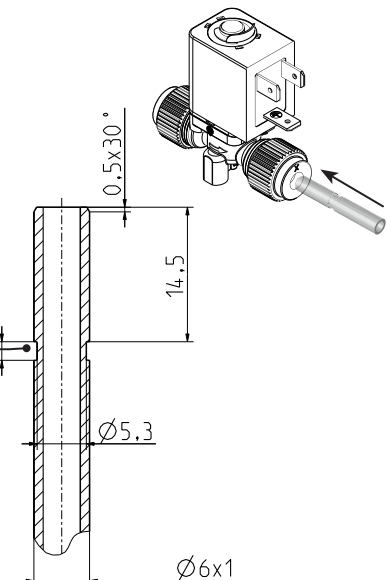







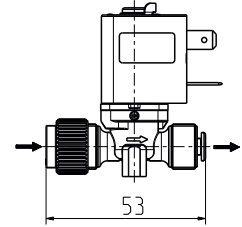
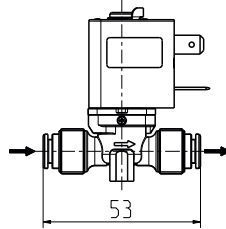
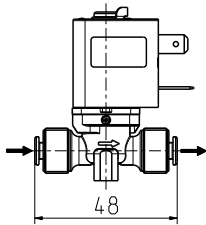

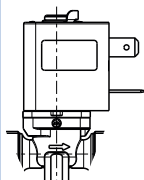

Series 18.00x.001

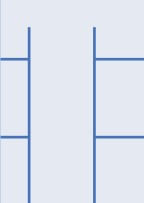
Alternative Connections



Please refer to our Fitsys 18 data sheet for additional valve connection options.

Type		Inlet		Outlet
G	Push-Fit connection Ø 4 mm			
F	Push-Fit connection Ø 6 mm			
E	Clamp connection Ø 6 mm			

Connections can be combined arbitrarily.

Each in- and outlet can be configured

ID	DN	Cv-value	Inlet	Outlet	p-Operating	
					bar in flow direction	bar against flow direction
087715	mm	l/min	E	E	0 - 8	0 - 3
087720			G	G		

All other orifice sizes and in-/outlet variants upon request.



Series I8.00x.001

Any configuration of bank valves can be realized by combination of only four manifold versions using push-fit connection 6 mm Ø.
No tools are necessary.

Manifold system for Push-fit connection Ø 6 mm

Configuration examples

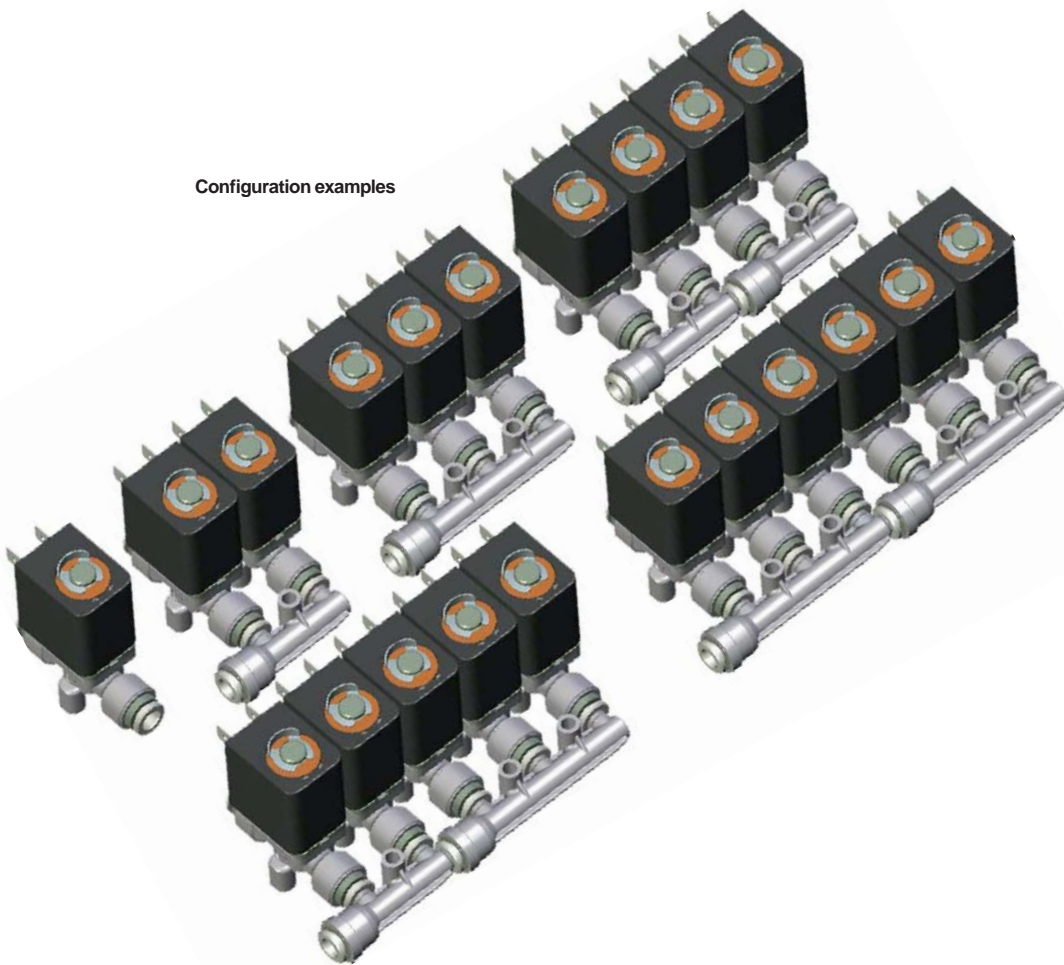

In addition to hot water the system is also suitable for saturated steam applications up to a temperature of 143° C.

A fixed relation between pressure and temperature exists for saturated steam, as is shown in the adjacent diagram.

Pressure-temperature diagram for saturated steam

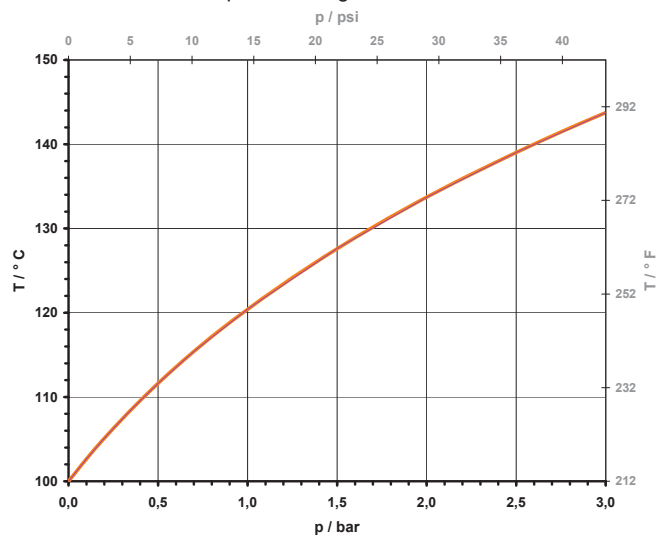



Series 18.00x.001

Manifold components for Push-fit connection 6 mm Ø

Flow direction (→) also reversed possible.

Type	Figures		ID
	* Area of o-ring seal	Flow direction (→) can also be reversed.	
MC-F.C.C			008948
MC-F.C.C.C			008949
MO-F.C.C.C			008946
MO-F.C.C.C.C			008947



Series I8.00x.001

Example of mounting for valves and manifold components on a mounting plate.

